

# DEVELOPMENT APPLICATION INFORMATION SHEET - FRONT FENCES

This information sheet summarises and explains Council's requirements in regards to Front Fences which must be complied with.

## The following forms must be completed

- Application for Approval Form
- Development Application Checklist

## The following controls shall be considered

A front fence is a fence constructed in front of the dwelling which must meet the following requirements;

- Be of constructed of brick with decorative infill panels and have a maximum height of 1.5 metres above ground level (existing).
- Step down and follow the natural contours of the site.
- Infill panels and decorative inclusions must not be made out of reflective materials and must be open to permit views into the front yard and the façade of the dwelling.
- The maximum height of the brick wall portion of the front fence is 900mm above ground level (existing), with the exception of the brick piers.
- Be constructed wholly within the property boundary.
- Gates should be consistent with the infill panels and not open onto a roadway or public space.
- Along major roads such as The Horsley Drive, Cumberland Highway and Cabramatta Road, solid front fences with a maximum height of 1.8 metres are permitted with the provision that the fence incorporates corners and planting beds every 5 metres.
- Fences must not stop or redirect surface waters.

### Elevation Examples:

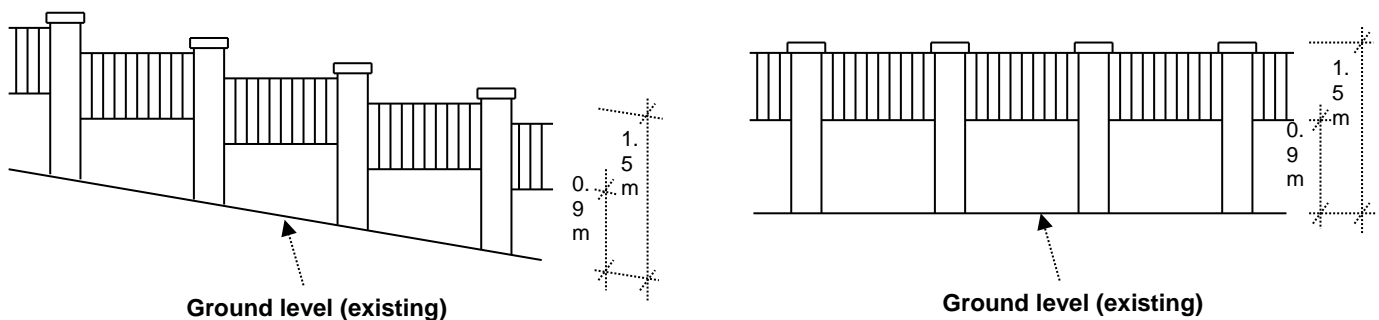

**The front fence must follow the natural contours of the site**

## Site Plan Example:

Site Plan scale needs to be 1:200

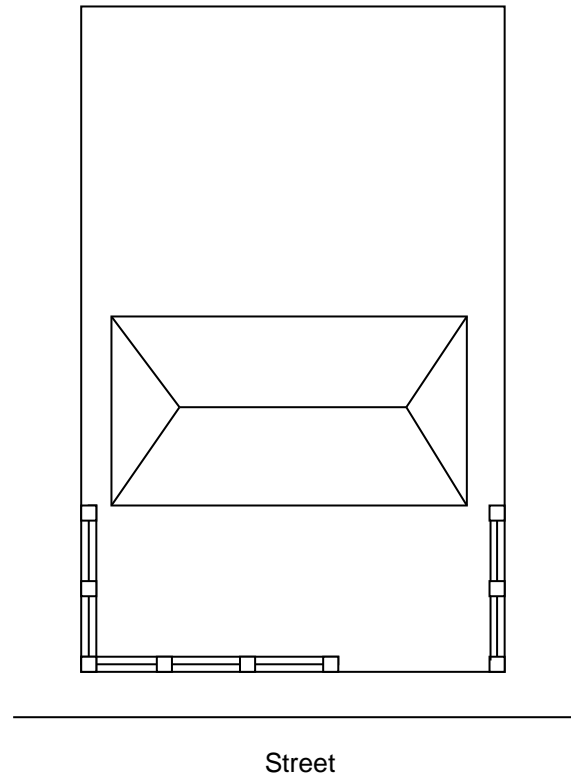

## For further information

Should you require additional information or advice, please contact Council's Customer Service team on 9725-0222.

Copies of forms and checklists to be completed and submitted with a Development Application are available at Council's Administration Centre or alternatively, visit Council's website to access forms, checklists and DCP's.